

lighthub
DIRECT.COM

INSTALLATION & SAFETY INSTRUCTIONS



MODEL: BHEM5

**These instructions are for guidance only
Read these instructions fully before using the fitting.
Retain these instructions for future reference.**

LIGHT MUST BE INSTALLED BY A QUALIFIED ELECTRICIAN

General safety instructions

- Ensure mains power is disconnected & switched off when installing the fitting.
- Never look directly into the LED light source. The light emitted can contain the colour blue.
- To clean: Ensure that the fitting is disconnected from the mains and cannot be unintentionally reconnected.
- Place only upon level and stable surfaces.
- Do not use in areas in which there is a danger of explosion.
- Do not use near flammable materials.
- Do not place in water or other liquids.
- Never operate with wet hands.
- Never cover the equipment.
- Never operate when the casing is open, or when the wiring casing is missing or damaged, or when the protective screen is defective.
- Never spray this unit, and never attempt to clean it with a steam pressure cleaner as this can damage the insulation and seals.
- Never attempt to repair this unit yourself. Repairs should only be carried out by a qualified electrician.
- If the supply cable is damaged, stop using the unit immediately & consult a qualified electrician.
- If diffuser is broken, stop using the unit immediately & consult a qualified electrician.



	BHEM5
Wattage	5W Maintained / 3W Non-Maintained
Lumens	220 lm
LED Life	50,000 hrs
LED Colour Temp	6500K
Beam Angle	120°
Voltage	180-240V AC 50Hz
Operating Temp	-20° C to +45° C
CRI	80
IP Rating	IP65
Battery run time	>3 hours
Construction	White polycarbonate
HxWxD	355x110x70mm
Guarantee	Product - 3 years* / Battery - 2 years*
Class	II

This luminaire contains built-in LED lamps.

The lamps cannot be changed in the luminaire.

LightHub BHEM5 874/2012

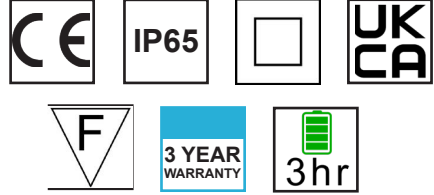

Recommendations

- Installation should be carried out in accordance with the latest IEE (BS7671) Regulations & the latest Buildings Regulations. Please consult a qualified electrician.
- Guidance on the installation of Emergency lighting in the UK is available from the BSI, regulation: BS 5266-1:2016.
- Please ensure the mains supply is switched OFF before installing and working on this fitting.
- This unit is Class II rated and does not require an earth connection.
- Not suitable for use with dimmers.
- The fitting is suitable for use in ambient temperatures of -20 to +45 degrees C. If the fitting is installed in locations where the temperature may vary beyond these temperatures or reach these limits for prolonged periods, the battery life may be shortened and should be tested more regularly.
- This fitting can be used indoors and outdoors.
- High voltage insulation test equipment must not be used on this fitting and may cause irreparable damage.
- It is recommended that 100mm of air space is left around the unit.
- This unit has no replaceable parts.
- The battery must be charged for 24 hours before the fitting can be commissioned.

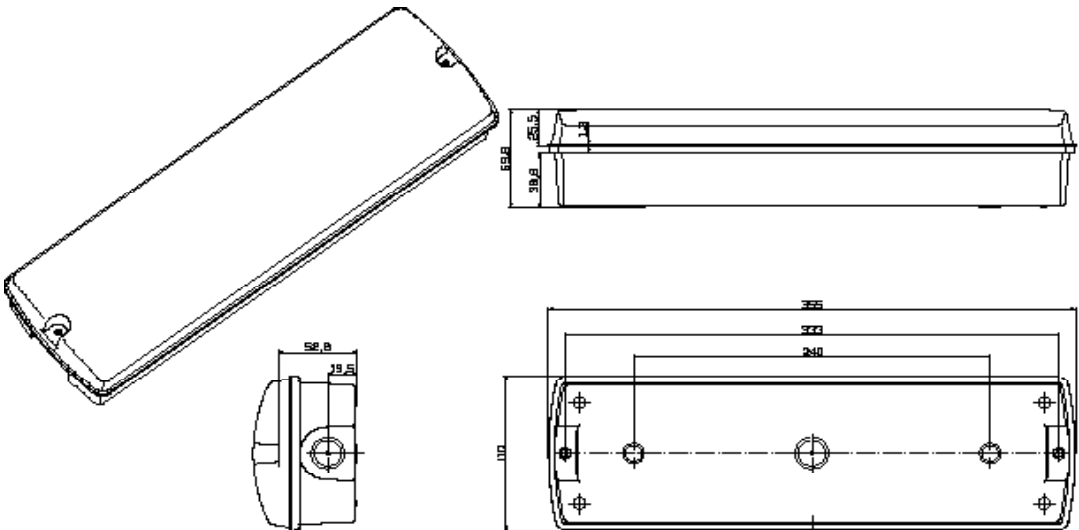

Installation Instructions

1. Ensure the electrical supply is switched OFF before working on this fitting.
2. A key switch or other suitable security switch should be installed to simulate a power failure to the fitting for monthly testing.
3. Release the front cover by unscrewing the cover screws. To release the gear tray, push the tabs protruding through. The gear tray hangs on hinges for convenient fitting and wiring.
4. Choose a suitable cable entry point on either side of the fitting. Using a hole saw, drill out the required knockout.
5. Insert the supplied grommet in the cable entry hole to stop cables being frayed. Alternatively, 20mm conduit or a compression gland can be used in these knockouts.
6. Drill out the 2 screw holes in the indicated positions in the base of the fitting.
7. Mark mounting holes on the ceiling, using the fitting as a template. Drill out 5mm holes and insert the supplied wall plugs or suitable plasterboard plugs if in a plasterboard ceiling.
8. Screw the fitting to the ceiling.
9. Feed the supply cable into the fitting.
10. Connect the 4 PIN connector from the battery to the circuit board.
11. Mark the battery with the commissioning date.
12. Strip the wires and connect as follows:

Non-Maintained Operation: The fitting is supplied from a permanent Live only. In the event of a power failure, the fitting fails over to the battery pack and the light switches on. The supply can be interrupted by a test switch to simulate power failure.

Permanent Live - (L) Brown
Earth - (E) Green/Yellow (Not Required)
Neutral - (N) Blue

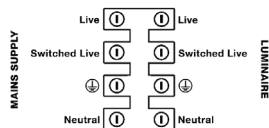

Maintained Operation: The fitting is switched or permanently on. In switched operation, a switch can be installed to the Switched Live. Connect a Permanent Live feed and the switch to Switched Live. For an unswitched circuit, connect the Permanent Live and insert the supplied loop between PL and Switched Live. In the event of a power failure, the fitting fails over to the battery pack and the light switches on.

Permanent Live - (L) Brown & Insert a Loop to Switched Live.
Earth - (E) Green/Yellow (Not Required)
Neutral - (N) Blue

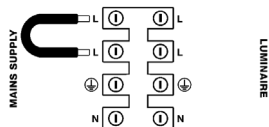

13. Please ensure the fitting is disconnected when carrying out insulation resistance testing at voltages above 250V.
14. Replace the cover.
15. Switch on the power supply and check the battery charge indicator inside the diffuser illuminates.
16. When first installed, allow 24 hours minimum to obtain full battery charge.
17. After the charging period, disconnect the mains supply to ensure that the fitting illuminates in emergency mode

WARNING:

This luminaire MUST be disconnected before it is installed, subjected to any high voltage or subjected to insulation resistance testing. Otherwise irreparable damage will occur to luminaire components.

Cleaning

Before cleaning the fitting, disconnect the power cable and allow the fitting to cool down sufficiently. Clean with a dry or slightly moist, clean, lint-free cloth and a mild detergent if required. Do not use cleaners that contain abrasives or solvents.

Maintenance

- Check power cable and housing of the fitting for damage before use. If the diffuser is damaged, unit must be replaced immediately.
- Clean any dirt from the housing or the diffuser immediately, it could potentially cause overheating.

Correct Disposal of this product

 This marking indicates that this product should not be disposed with other household wastes throughout the EU. To prevent possible harm to the environment or human health from uncontrolled waste disposal, recycle it responsibly to promote the sustainable reuse of material resources. To return your used device, please use the return and collection systems or contact the retailer where the product was purchased. They can take this product for environmental safe recycling.

Testing Instructions

- Emergency light fittings must be inspected and tested regularly in accordance with local codes of practice. For safety reasons, tests should be carried out during daylight hours.
 - The minimum recommended test schedule is as follows:
After installation, allow minimum 24 hours to ensure full battery charge. Then interrupt the supply and check after 3 hours that the fitting is still illuminated.
- Daily check that the charge indicator LED is working
 - Every month, interrupt mains for a short period and check that fitting lights
 - Six-monthly, check 1 hour duration
 - At the end of year 3 and subsequently every year, check 3 hour duration; batteries must be replaced when they can no longer support 3 hour duration.
 - Complete the record sheet on installation and retain in a maintenance file
 - Update the file with ongoing test records for inspection by a fire officer or other duly authorised person.

INSTALLER:	LOCATION:	INSTALLATION DATE:
-------------------	------------------	---------------------------

Month	Test	1st Year		2nd Year		3rd Year		4th Year		5th Year	
		signed	date	signed	date	signed	date	signed	date	signed	date
1	short										
2	short										
3	short										
4	short										
5	short										
6	short										
7	short										
8	short										
9	short										
10	short										
11	1hr							██	██	██	██
12	3hr	██	██	██	██	██	██				

Cleaning

Before cleaning the fitting, disconnect the power cable and allow the fitting to cool down sufficiently. Clean with a dry or slightly moist, clean, lint-free cloth and a mild detergent if required. Do not use cleaners that contain abrasives or solvents.

Maintenance

- Check power cable and housing of the fitting for damage before use. If the diffuser is damaged, unit must be replaced immediately.
- Clean any dirt from the housing or the diffuser immediately, it could potentially cause overheating.

Correct Disposal of this product

This marking indicates that this product should not be disposed with other household wastes throughout the EU. To prevent possible harm to the environment or human health from uncontrolled waste disposal, recycle it responsibly to promote the sustainable reuse of material resources. To return your used device, please use the return and collection systems or contact the retailer where the product was purchased. They can take this product for environmental safe recycling.

